



// 2024

Automotive industry tooling solutions



GANZHOU ACHTECK TOOL TECHNOLOGY CO.,LTD.

Add: Ganzhou Economic Development Area, Jiangxi, China
Tel: 400-9150-887 Fax: 0086-797-8166100 E-mail: marketing@achtecktool.com



ACHTECK AMERICA, INC.

Add: 1928 Star Batt Drive, Ste C, Rochester Hills, MI 48309
Tel: +1(947)208-7289 E-mail: zyaacs@achtecktool.com Website: www.achteckamerica.com

2024V01

www.achteckamerica.com



Company Profile

Ganzhou Achteck Tool Technology Co., Ltd. is a wholly-owned subsidiary of Chongyi Zhangyuan Tungsten Co., Ltd. (Listed Company with stock code 002378). The registered capital of Achteck is 1.66 billion USD with 800 employees. The main products include: Coated Carbide Inserts, Carbide Rod and supporting tool holders. Achteck is known for its outstanding R&D competence, production & testing equipment and its coated carbide insert production technology.

Achteck produces inserts for Turning, Grooving, Milling and Drilling that are widely applied in automotive, energy, die & mold, general machinery, aerospace and other industries. Achteck Tool is technology oriented, owns a strong research team that keeps on innovating. Having "Benefits from Resources, Reliance on Technologies, Devotion to Humanity and Top with Trust" as the operating philosophy and "Safety, Harmony, Efficiency and Innovation" as the target, Achteck aims to become a well-known brand in the world and a first-class cemented carbide manufacturer in China.



Contents:

Cylinder blocks	1-6
Cylinder head	7-10
Turbo charger shell	11-12
CAM shafts	13-14
Caliper brackets	15-16
Caliper	17-20
Crank shafts	21-22
Connecting rods	23-24
Valve lifters	25-26

• Cylinder blocks
Material: Cast iron



Application: Top and bottom faces rough milling
Solution: 1. Achteck AFM45/75/88-SN12
2. Achteck AFM45-XN07/09
3. Achteck AFM45-XN09-W

- Cutter diameter range: D63-250mm
- Wedge clamping XNMF 09 insert, reliable insert clamping
- Grades AC301K/AP251K for cast iron milling



Application: Side boss milling
Solution:
1. Achteck APE90-LN09/LN13
2. Achteck ASM90-LN09/LN13
3. Achteck ASM90-WN08
4. Achteck AFM88-SN12
5. Achteck ASM90-LN12

- Tangential milling insert with spiral cutting edge
- Precise internal coolant for each insert
- APE90 with tangential design with high cutting strength and high reliability



Application: Cylinder bore rough boring
Solution: Achteck special cutter+SN12 or LNET12 standard insert
➤LN12 insert with 4 left and 4 right cutting edges
➤Double sided SN12 insert with 8 cutting edges, highly economical



Application: Finish face milling
Solution: Achteck AFF40-LN12/LN15

- Close pitch design with a 40° approach angle
- Negative insert with 16 cutting edges, highly economical
- The blackened tool body has good appearance and corrosion resistance
- Precision adjustable cartridges for the wiper inserts ensures the highest quality surface finish



Application: Drilling
Solution: Achteck solid carbide D106 drills with internal coolant

- Composite nano-coating, high wear resistance and toughness
- Different diameter choices of 3xD, 5xD and 8xD

- Cylinder blocks
Material: cast aluminum alloy



Brazed PCD milling cutter

- Provide special design
- Multi-functional face milling cutter for various applications
- The special cutting edge for the mesh stripes effect
- Provide grinding services to ensure product quality, highly economical



PCD face milling cutter with adjustable cartridges

- For finish machining
- Close pitch design for high efficiency, adjustable cartridges for high precision
- Repairable and replaceable cartridges, reusable cutter, highly economical

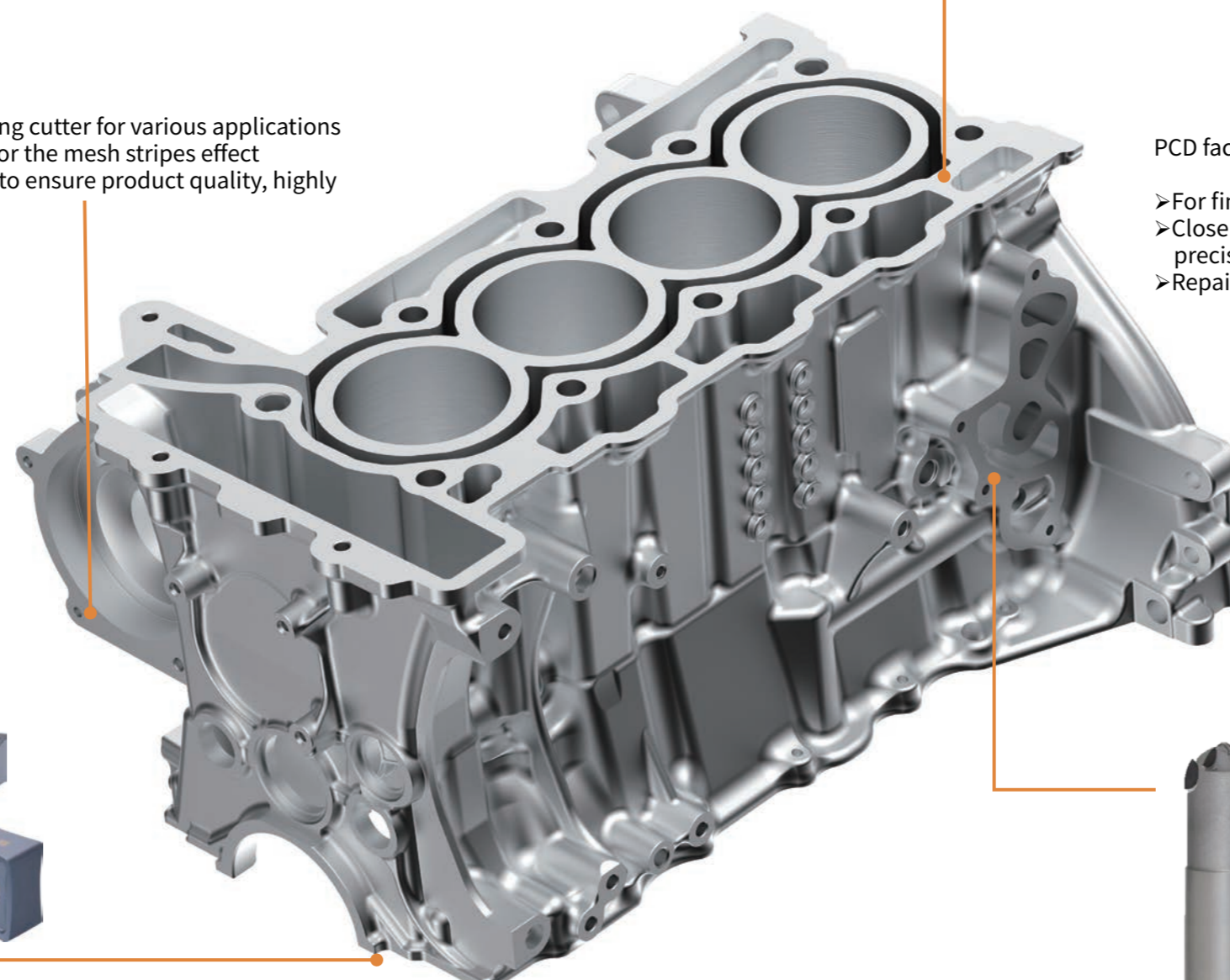

AFM88-SN12 series face milling cutter

- Cutter diameter: from 50mm to 315mm
- Large cutting depth and high feed for high efficiency
- SN..1206 insert, 8 cutting edges, with the grade AW100K for aluminum alloys, high efficiency and low cost

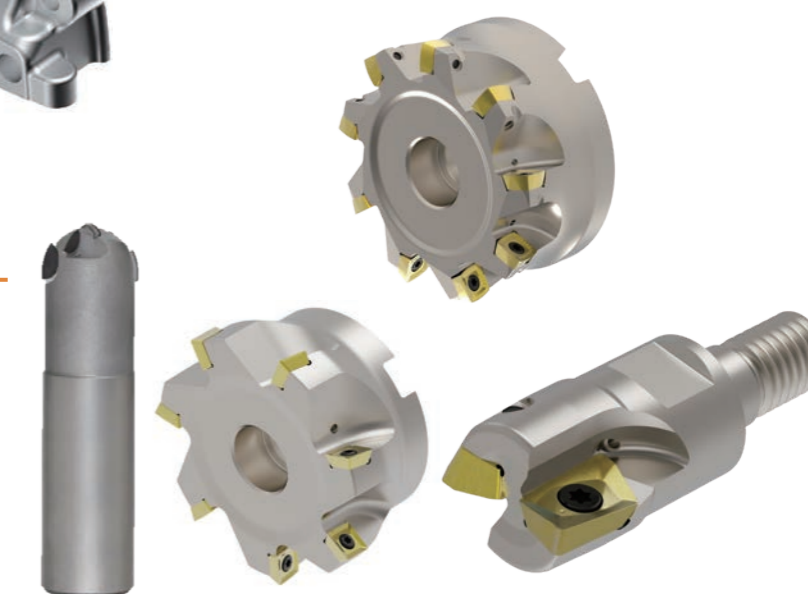

ASM shoulder milling series, APE90 porcupine milling cutter series, AHM high-feed milling cutter, special brazed PCD milling cutter

- Suitable for different milling conditions
- Excellent performance and long tool life

• Cylinder blocks
Material: cast aluminum alloy



Application: Bearing hole finish/rough boring

- High stability and compact structure design ensures the rigidity of the tool while minimizing the weight of the tool
- With precision adjustment for the rapid adjustment of machining size
- Balanced wear resistance and toughness, excellent surface finish of PB90



PCD reamer

- Tool diameter 4~20mm, cutting edges 2~6
- Used cemented carbide as the matrix to ensure the rigidity of the tool
- Balanced wear resistance and toughness for high tool life with PD20 grade and special cutting edge design

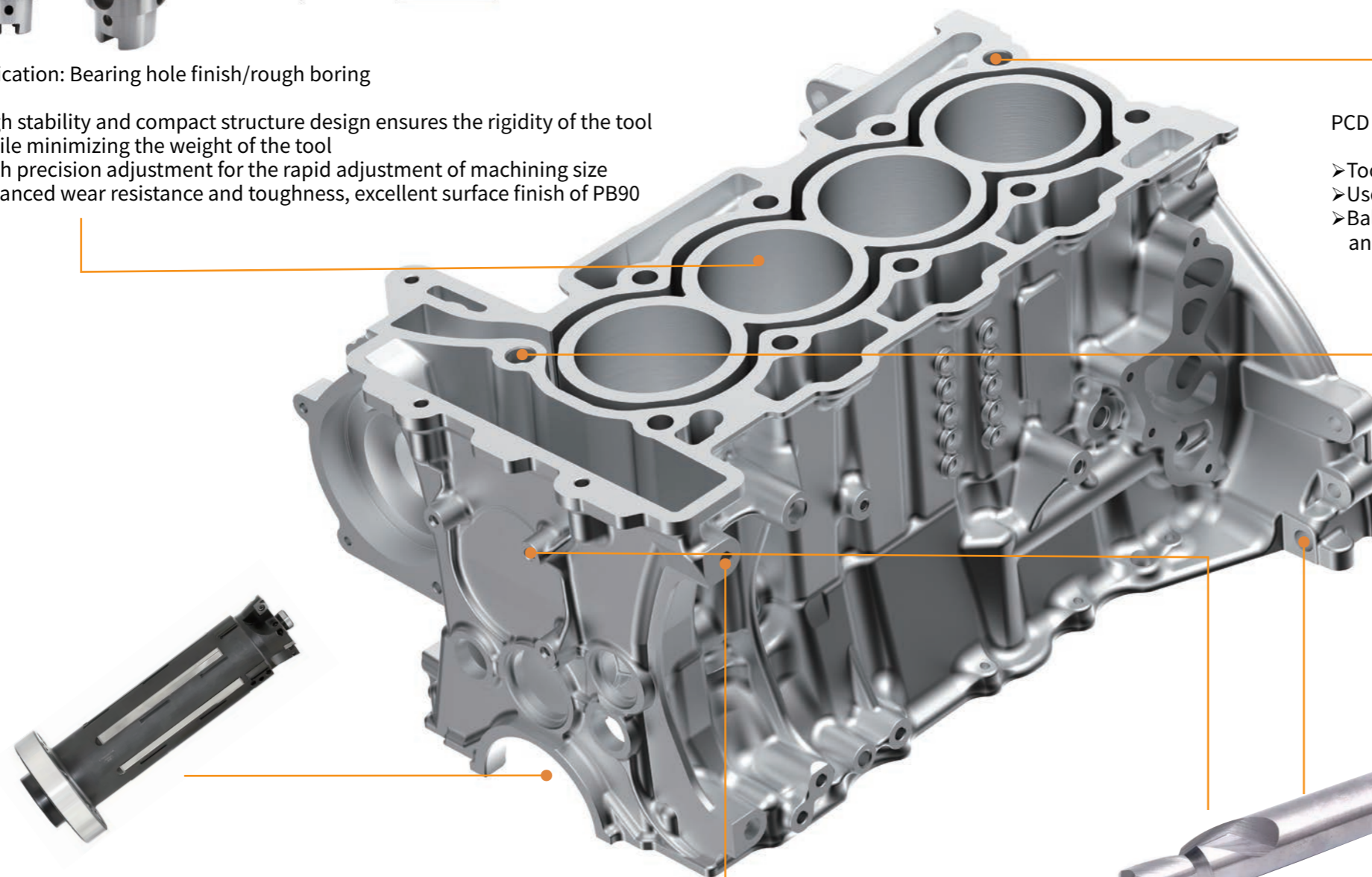

CAM shaft hole finishing

- Flange coupling, tool holder with guide pads, suitable for various applications
- High precision and excellent tool life

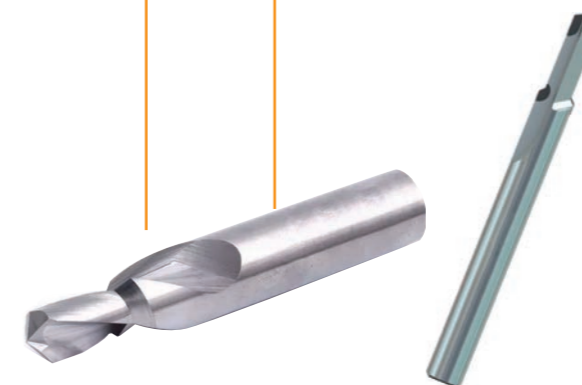

Step drill

- Provide special design
- Solid carbide and brazed PCD options
- Uses self-developed ultra-fine grain carbide rod for added precision
- High wear resistance ensures long tool life

• Cylinder head
Material: cast aluminum alloy



Value seat machining

- Machining special valve seat profile
- Machine multiple angles at one time, highly efficient and stable
- Number of cutting edges balanced between PCD and PCBN for excellent tool life



PCD face milling cutter with adjustable cartridges

- For surface finishing
- Close pitch design for high efficiency, adjustable height of cartridges for high precision
- Repairable and replaceable cartridges, reusable cutter, highly economical

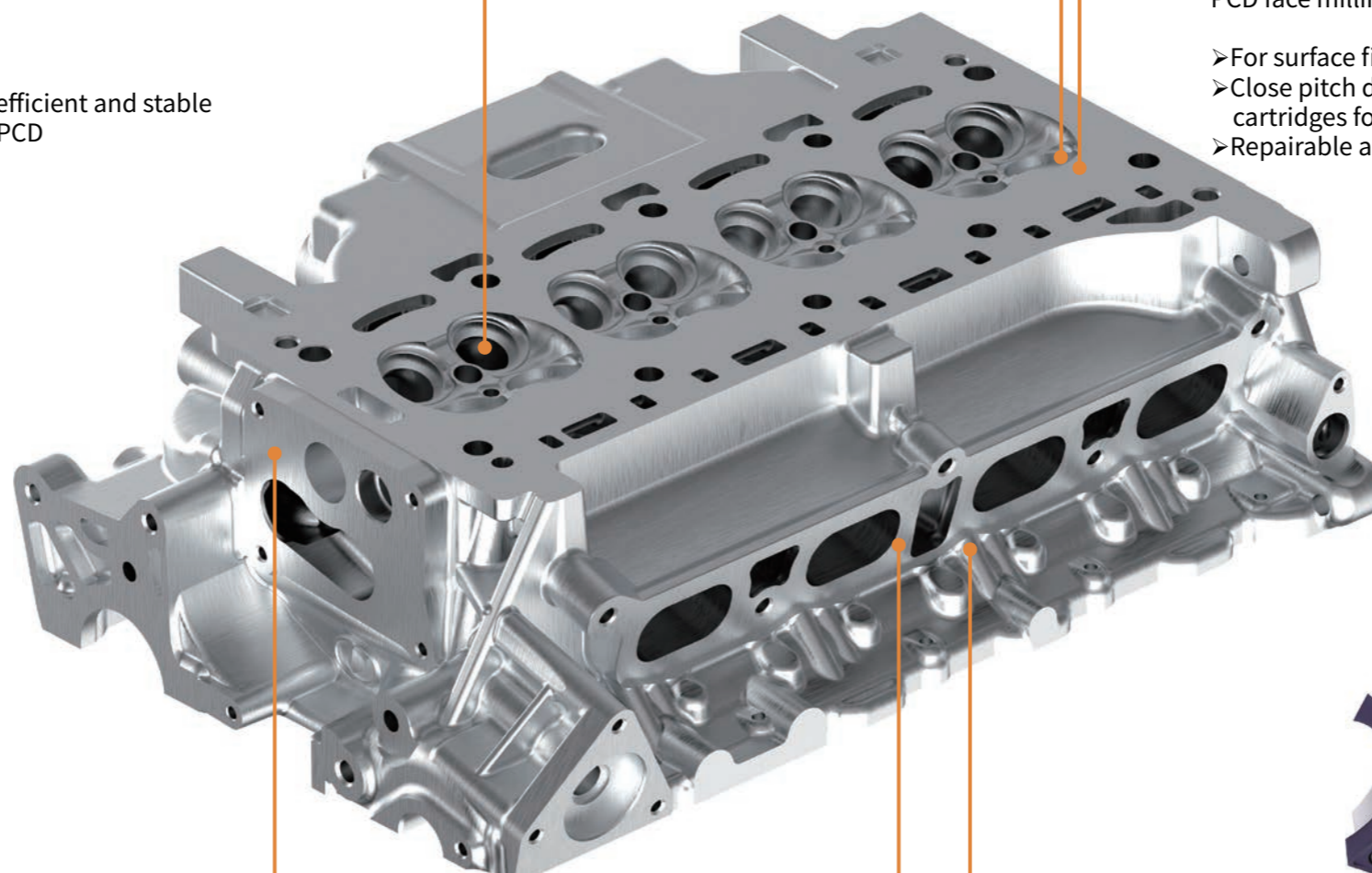

Brazed PCD milling cutter

- Provide special design
- Multi-functional face milling cutter for various applications
- The special cutting edge for the mesh stripes effect
- Provide grinding services to ensure product quality, highly economical



AFM88-SN12 series face milling cutter

- Cutter diameter: from 50mm to 315mm
- Large cutting depth and high feed for high efficiency
- SN..1206 insert, 8 cutting edges, with the grade AW100K for aluminum alloy, high efficiency and low cost

- Cylinder head
Material: cast aluminum alloy



Camshaft boring tool with guide pads

- Provide special tool
- With ISO standard inserts
- With guide pads, good stability and high precision



Nozzle hole machining
Special tool

- Provide special design
- Machining multiple diameters at one time, high efficiency
- Laser-ground edge for dimensional stability
- Multiple internal coolant holes for sufficient coolant

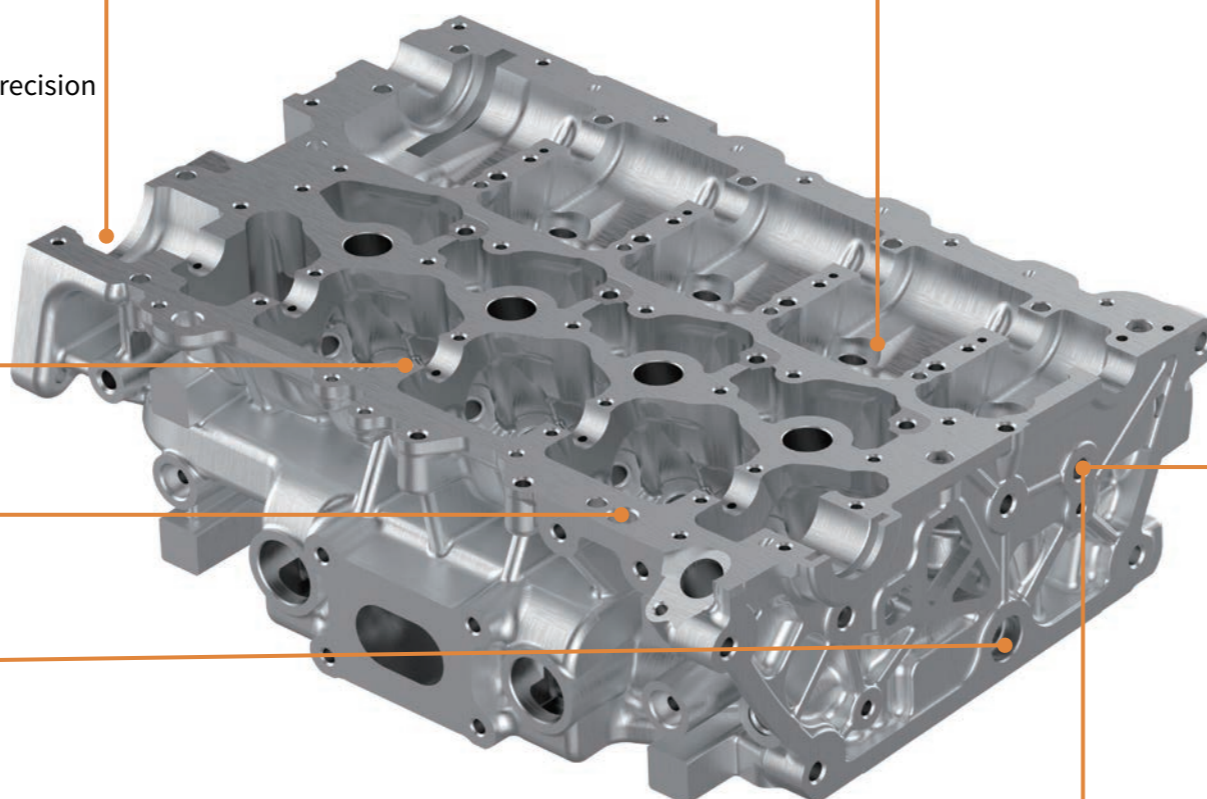

PCD reamer

- Tool diameter 4~20mm, cutting edges 2~6
- Used carbide shank to ensure the rigidity of the tool
- Balanced wear resistance and toughness for long tool life with PD20 grade and special cutting edge design



Peripheral hole machining
Step drill

- Provide special design
- Solid carbide and brazed PCD options
- Uses self-developed ultra-fine grain carbide rod for added precision
- High wear resistance ensures long tool life



Cutting taps and forming taps

- The fine-grained monolithic carbide rod for excellent tool life
- The optimized cutting edge design for low friction and excellent thread quality

• Turbine shell
Material: Heat resistant stainless steel



Application: Flange face reverse milling
Solution: Achteck special side milling cutter
➤ Negative insert double sided, very economical

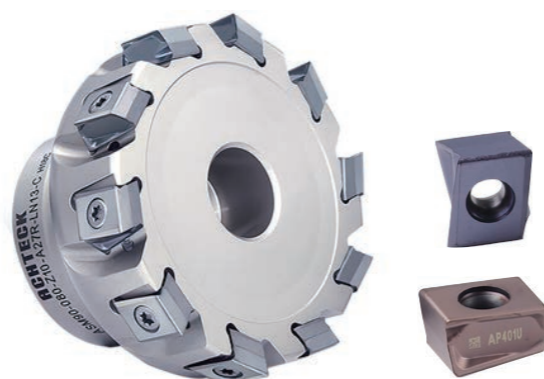

Application: Boss surface milling
Solution: Achteck ASM90-LN09/13 ASM90-WN08
➤ Good perpendicularity
➤ Tangential insert, high strength, good reliability



Application: Middle hole rough boring
Solution: Achteck Special boring tool
➤ CCMT 09T308E-KC2
➤ SCMT 09T308E-KC2
➤ Grade: AP301M



Application: Flange surface rough milling
Solution: Achteck AFM45-XN07/AFM40-0N05
➤ Negative insert, double-sided, highly economical
➤ Special cutters with insert shims available
➤ Optional Grades: AC3015/AP3028

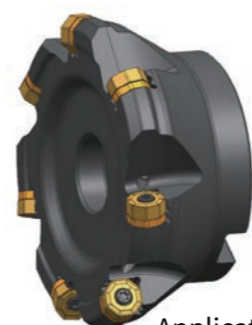

Application: Finish milling on flange surface
Solution: Achteck AFF45-0N05-C-S
➤ The cutter with insert shims, more reliable
➤ Cutters available with black oxide coating
➤ Grades: AP2921/AP2932

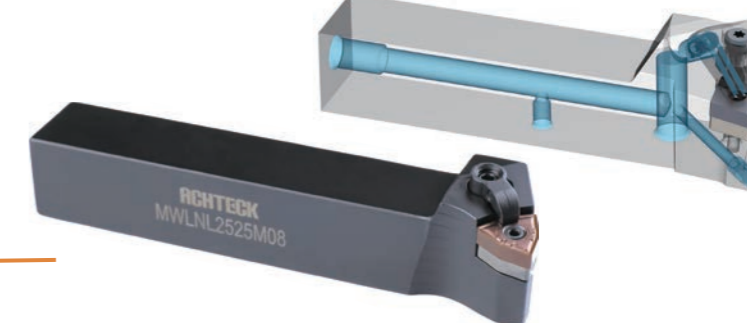

Application: External, internal rough and finish turning
Solution: Achteck ISO standard turning insert
➤ Multiple grades available: AP100S/AP200M/AC100M/AC200M
➤ Tool holder with high-pressure internal cooling for difficult-to-machine materials



Application: Face grooving, external grooving, V-shaped grooving
Solution: Achteck ATD flat head and ball nose grooving insert
➤ Good perpendicularity

- CAM shafts
Material: Alloy steel



Application: Cam OD milling
Solution: Achteck special tool solution

- Achteck Special design;
- With grade AP251U

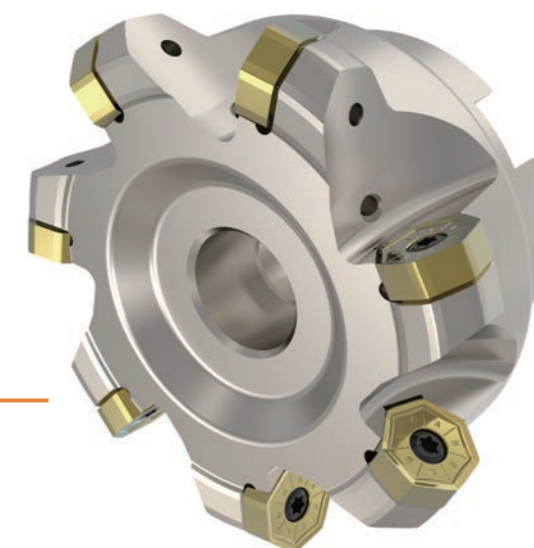

Application: End face milling
Solution: Achteck XN07 /09 series

- Versatile grade covers P, M, S
- Double sided insert with 14 cutting edges, very economical



Application: End face milling
Solution: Achteck M200 solid carbide end mill series

- With universal grades

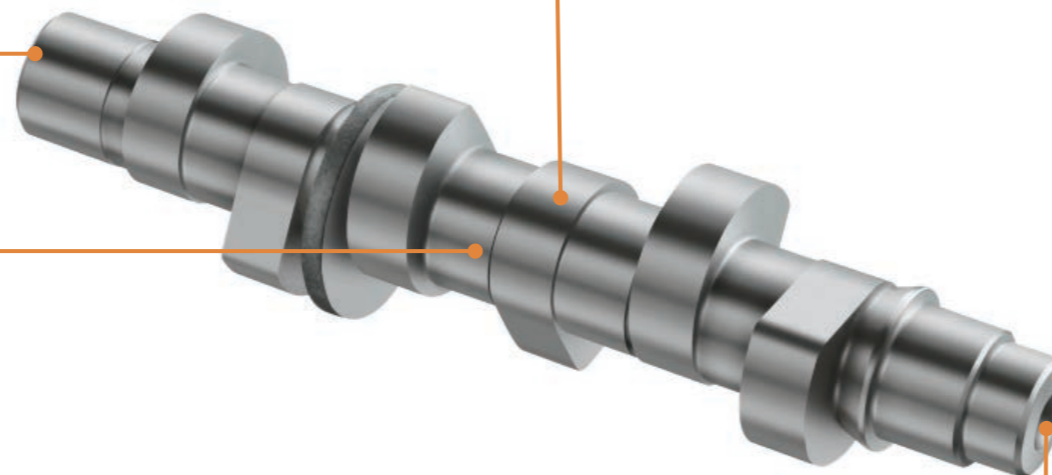

Application: External grooving, turning
Solution: Achteck ACD/ATD standard grooving inserts, VNMG turning inserts

- Insert with grade AP301U for good versatility
- With regular external turning/grooving holder

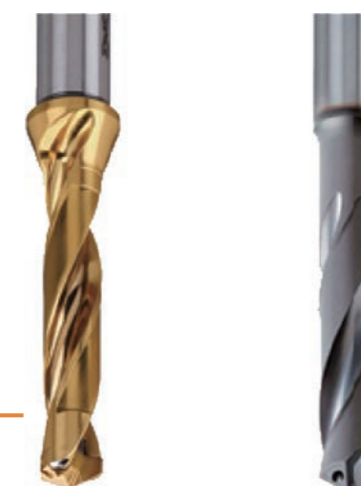

Application: Center hole drilling
Solution: Achteck modular drill series

- Modular drill
- Universal grade

- Caliper brackets
Material: Cast iron/aluminum alloy



Application: Slot milling
Solution: Achteck special product

➤Versatile grade covers P, M and S

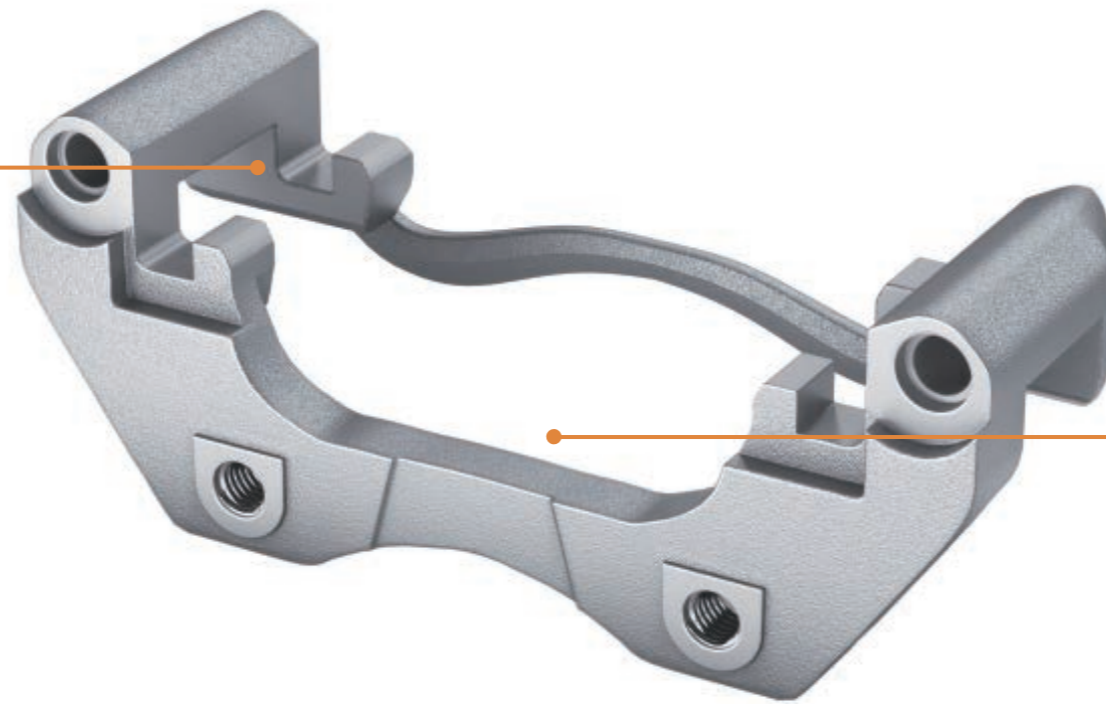

Application: Side milling
Solution: Achteck AP series

➤Grades : AP251K, AP251U

- Caliper
Material: Cast iron/aluminum alloy



Application: Drilling and tapping
Solution: Achteck special drill

- Special product design
- Tap

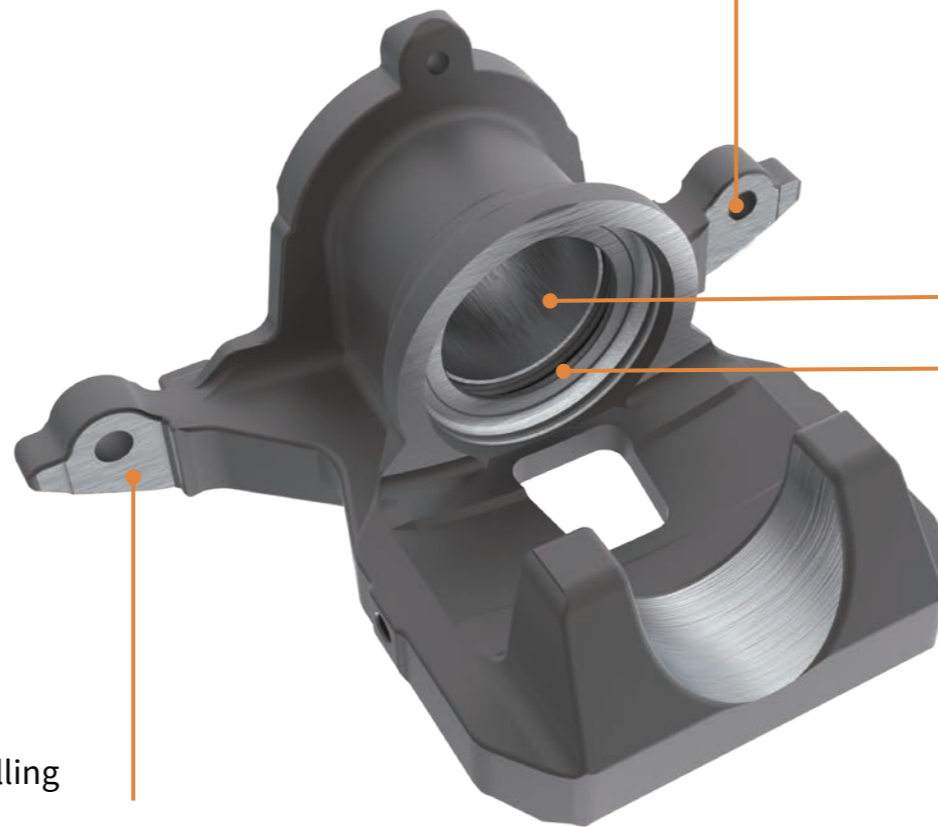

Application: Support lug surface drilling
Solution: Achteck special drill



Application: Piston hole rough boring
Solution: Achteck special cutter+standard insert

- SCMT12/09
- Special milling insert
- Grades: ACK15A, AC151K, AP251K



Application: Groove milling internal grooving piston hole
Solution: Achteck insert + special cutter

- Special milling insert
- Grades: AP251U/AP251K

- Caliper
Material: Cast iron/aluminum alloy

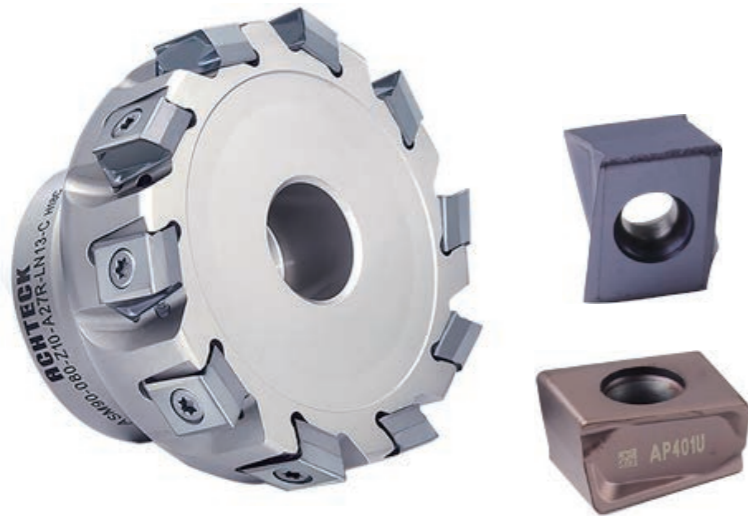

Application: Oil hole face milling
Solution: Achteck ASM90-LN09/13, AFM45-XN09-W cutters

➤Grade:AC301K, AP251K, AP351K

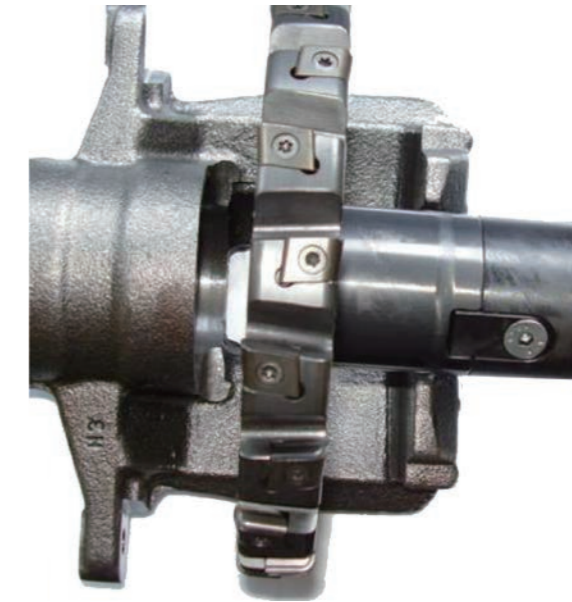

Application: Milling pad wall and disc clearance
Solution: Achteck special cutter+standard insert

➤SNGX 120612-MM4, special milling insert
➤Grades: AP251K, AC151K

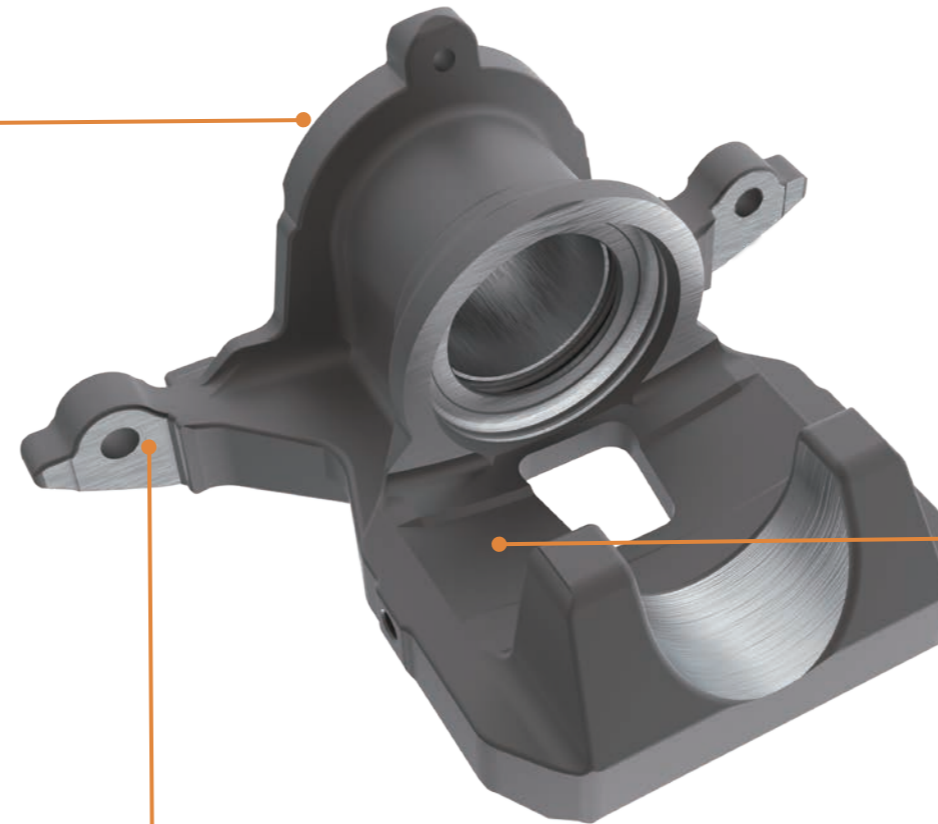

Application: Support lug face milling
Solution: Achteck special cutter+standard insert

➤Insert: LNET12 butterfly insert
➤Grades: AP251U, AP251K, AC151K

• Crank shafts
Material: Steel and cast iron

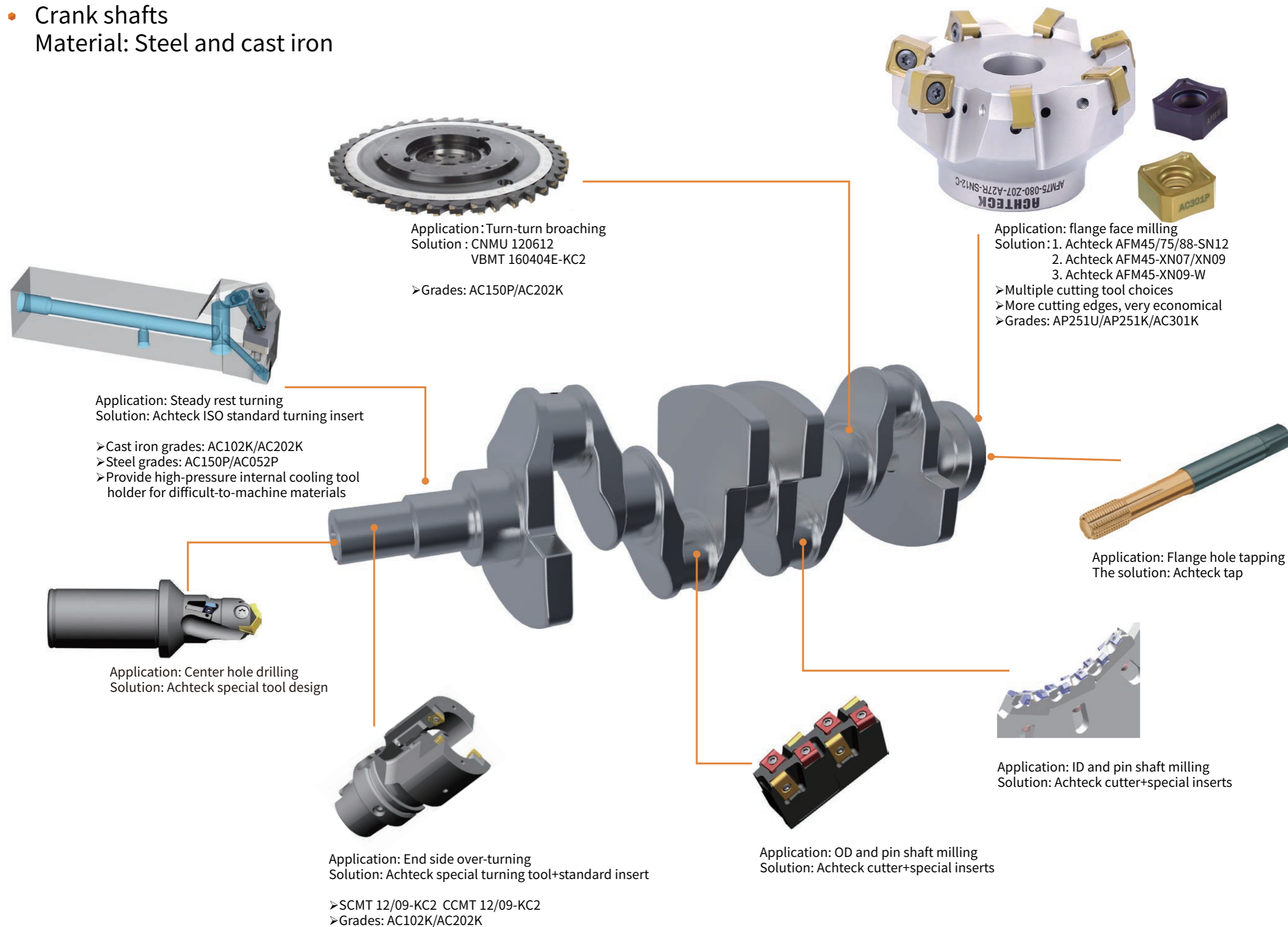

• Connecting rods
Material: Steel



Application: Bolt hole drilling
Solution: Achteck solid carbide drill D108 series with internal cooling

- Double-edges design
- Coated tip and polished flutes



Application: Big hole boring and chamfering on both sides
Solution: Achteck special tool body

- SCMT 09T308E-PC2
- Insert grades: AP200U/AP200M



Application: Small hole drilling
Solution: Achteck DP U drill inserts

- Insert grade: AP301U



Application: Bolt hole drilling
Solution: Achteck solid carbide drill D106 series with internal coolant

- Composite nano-coating, high wear resistance and high toughness
- Different options: 3xD and 5xD



Application: Small hole finish boring
Solution: Achteck special boring tool/cermet multi-edges reamer



Application: Small hole face milling and chamfer milling
Solution: Achteck special tool body

- SCMT 09T308E-KC2
- Insert grades: AP200U/AP200M



Application: Bolt hole face milling
Solution: 1. AchteckASM90-AD11
2. Achteck solid carbide end mill

• Valve lifters
Materials: Nickel based alloy

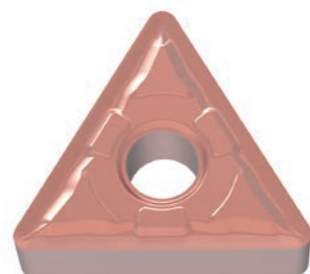

Application: Finish profile turning on neck
Solution: 1. WNMG 080408E-SC1/MB2
2. TNMG 160408E-SC3

- Negative insert with 6 cutting edges, highly economical with SC1/MB2 /SC3 geometries
- With grades AP100S and AP010S for heat resistant alloys

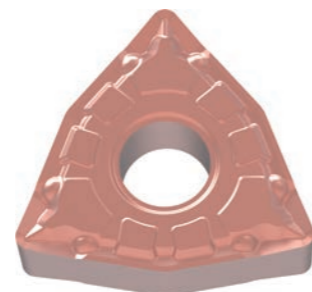

Application: Rough face turning+external turning
Solution: Achteck SNMG 120408E-MC3/MC4

- Negative insert with 8 cutting edges, highly economical, with MC3/MC4 geometries
- With grades AP100S and AP010S for heat resistant alloys

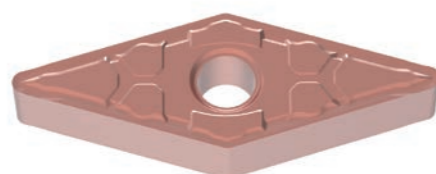
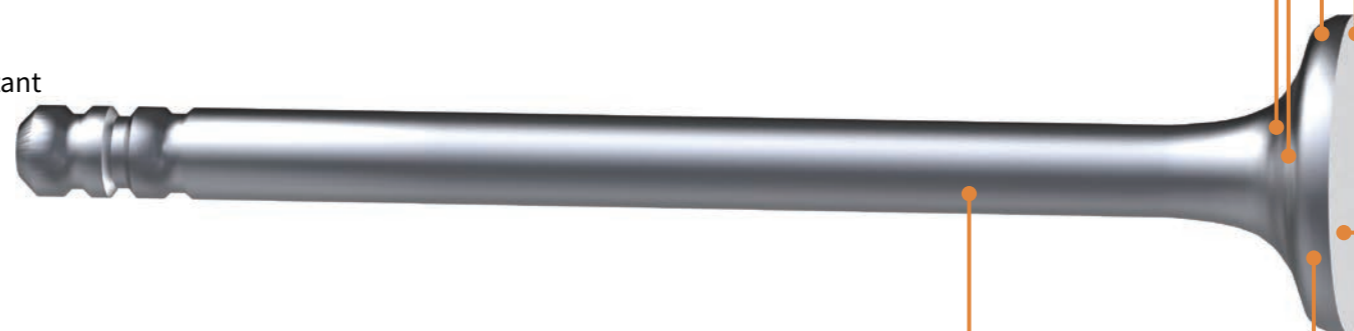

Application: Rough turning on welded slot
Solution: Achteck VNMG 160408E-MB2/SC3

- Negative insert with 4 cutting edges, highly economical, with SC3/MB2 geometry
- With grades AP100S and AP010S for heat resistant alloys

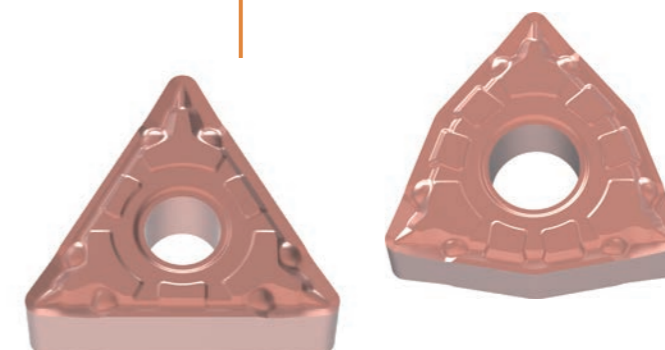

Application: Finish face turning+external turning
Solution: 1. Achteck TNMG 160408E-SC1/MB2
2. Achteck WNMG 080408E-SC1/MB2

- Negative insert with 6 cutting edges, highly economical with SC1/MB2 geometries
- With grades AP100S and AP010S for heat resistant alloys

